

Laser Systems > Beam Delivery System

Gaussian Beam Focused by Thermal Lens

Task/System Illustration

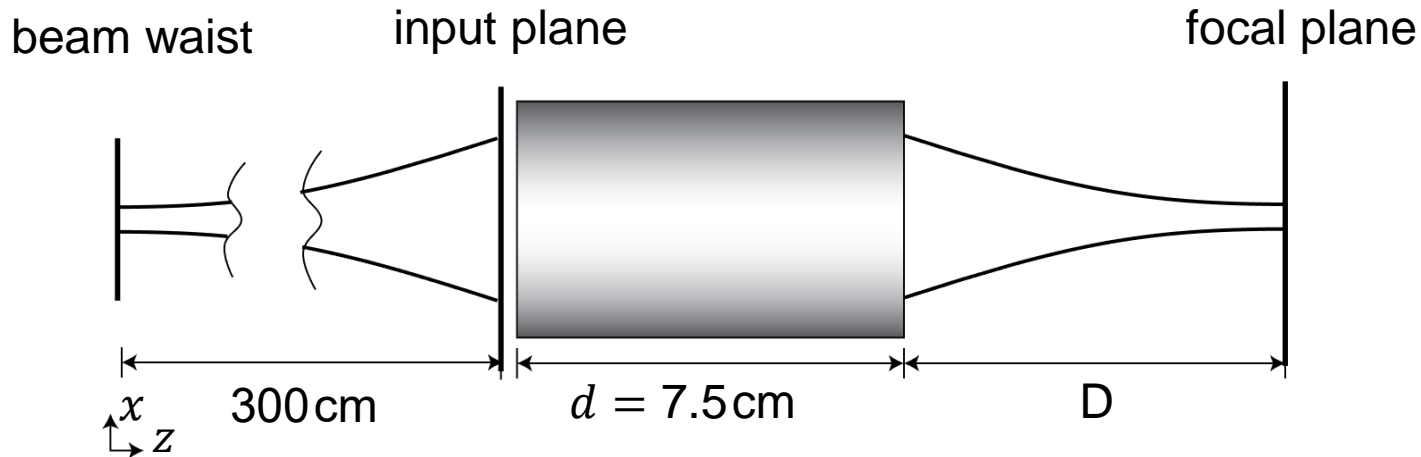

- simulation of a Gaussian beam focused by thermal lens effect induced by a high power laser.
- the refractive index $n(x, y)$ of the thermal lens changes with varying input power.

Highlights

- arbitrarily customizable refractive index profile
- using the Parameter Run document, users can simulate conveniently one system with varying parameters
- combination of different field tracing techniques

Specifications: Light Source

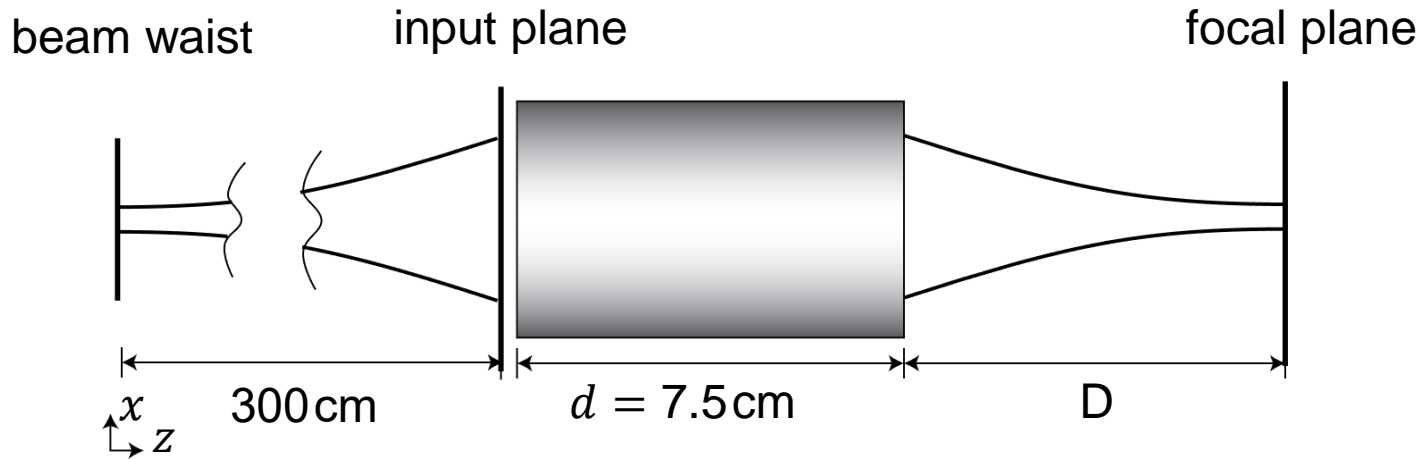

Parameter	Description / Value
coherence/mode	single Laguerre Gaussian (0,0) and (1,0) mode
wavelength	632.8 nm
polarization	linear in x-direction (0°)
beam waist radius	simulation 1: (0,0) mode: $760 \mu\text{m}$ simulation 2: (1,0) mode: 1 mm

Specifications: Thermal Lens

- Refractive index is

$$n(x, y) = n_0 - \frac{\eta P_{\text{in}}}{4K\pi d} \cdot \frac{\delta n}{\delta T} \cdot \frac{r^2}{r_0^2}$$

with $r = \sqrt{x^2 + y^2}$, r_0 and d are shown in the figure, P_{in} is input power, K , η and $\frac{\delta n}{\delta T}$ are temperature-related parameters which can be found in [1]

- Here the values are

- $r_0 = 0.31\text{cm}$, $d = 7.5\text{cm}$

- $K = 11.1\text{ W}/(\text{cm}^\circ\text{C})$, $\eta = 0.05$, $\frac{\delta n}{\delta T} = 7.3 \times 10^{-6}\text{ }^\circ\text{C}^{-1}$

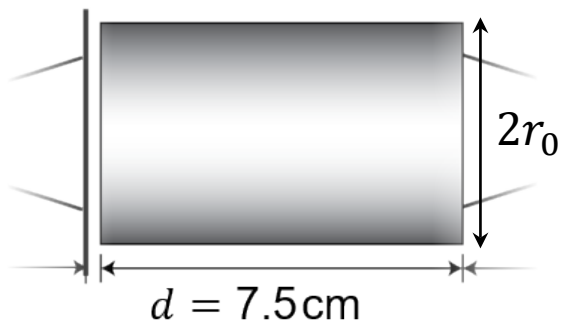

Highlight

arbitrarily customizable
refractive index profile

Specifications: Detector

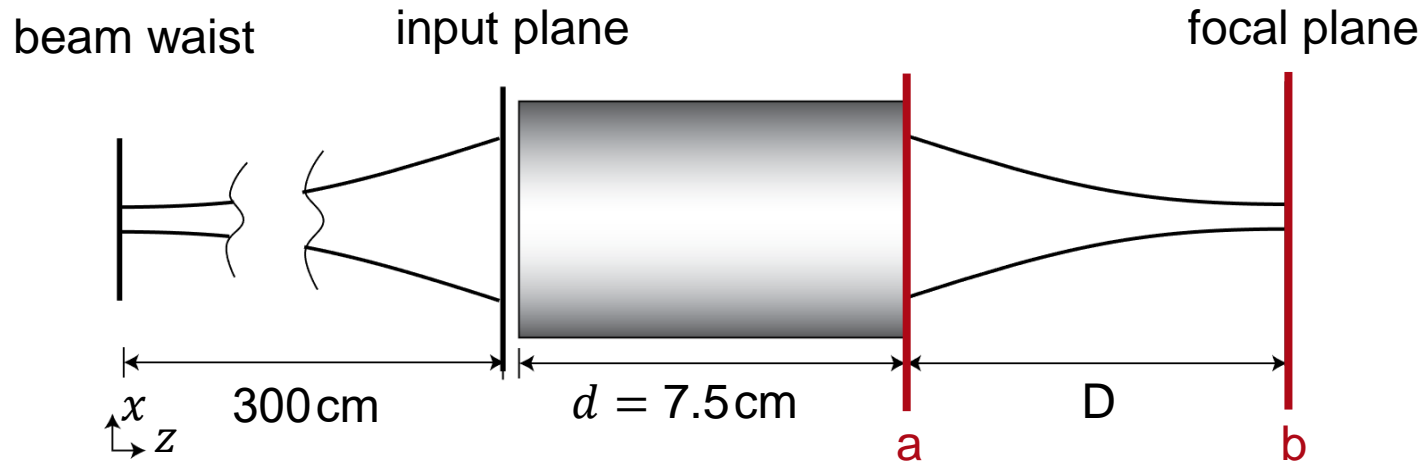

Position	Modeling Technique	Detector/Analyzer
a	field tracing	beam parameters for different input beams and input power values
b	field tracing	amplitude of E_x , E_y , E_z when input is (1,0) mode

Results: (0,0) Mode

- Using the *Parameter Run* document, one can calculate the output beam parameters for input powers varying from 8kW to 20kW. The detector is at position a .
 - Absolute value of *Waist Distance* (distance a with respect to b) is distance D .
 - Waist Diameter* is the waist diameter in focal plane (position b).

11: Parameter Run from 1: Light Path Editor (C:\Users\...\Example2.lpd #1)*

Results
Start the parameter run and analyze its results

Go!

Use Cached Results for Next Run

Detector	Subdetector	Combined Output	Iteration Step			
			1	2	3	4
Varied Parameters	P (Double Interface Compo...	Data Array	8 kW	9 kW	10 kW	11 kW
Beam Parameters #607 after Double Interface Component #1 (T) (Field Tracing 2nd Generation)	Waist Diameter X	Data Array	90.41921264 μm	80.34617646 μm	72.38992882 μm	65.57255852 μm
	Waist Diameter Y	Data Array	90.39943671 μm	80.36018607 μm	72.41032871 μm	65.56938795 μm
	Waist Distance X	Data Array	-225.3013984 mm	-197.8086613 mm	-175.972568 mm	-158.2061152 mm
	Waist Distance Y	Data Array	-225.3018184 mm	-197.8093367 mm	-175.9720342 mm	-158.2064622 mm

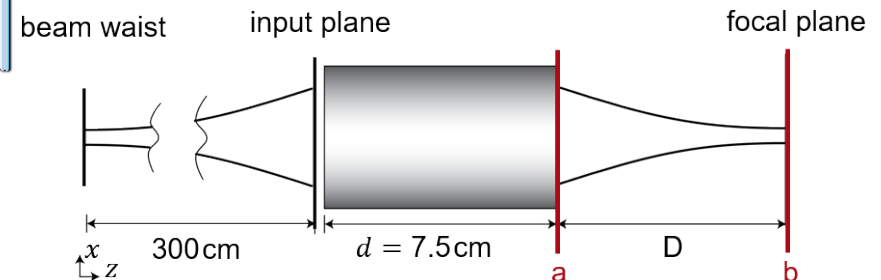

Results: (0,0) Mode

11: Parameter Run from 1: Light Path Editor (C:\Users\...\Example2.lpd #1)*

Results

Start the parameter run and analyze its results

Go!

Use Cached Results for Next Run

Detector	Subdetector	Combined Output	Iteration Step			
			1	2	3	4
Variied Parameters	P (Double Interface Compo...	Data Array	8 kW	9 kW	10 kW	11 kW
Beam Parameters #607 after Double Interface Component #1 (T) (Field Tracing 2nd Generation)	Waist Diameter X	Data Array	90.41921264 μm	80.34617646 μm	72.38992882 μm	65.57255852 μm
	Waist Diameter Y	Data Array	90.39943671 μm	80.36018607 μm	72.41032871 μm	65.56938795 μm
	Waist Distance X	Data Array	-225.3013984 mm	-197.8096613 mm	-175.972568 mm	-158.2061152 mm
	Waist Distance Y	Data Array	-225.3018184 mm	-197.8093367 mm	-175.9720342 mm	-158.2064622 mm

Highlight

simulate conveniently one system with varying parameters

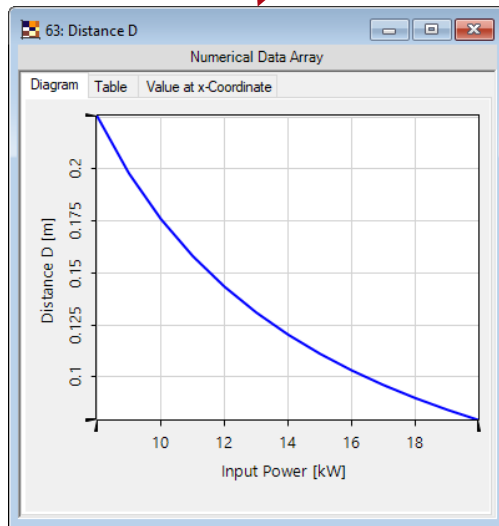

distance D

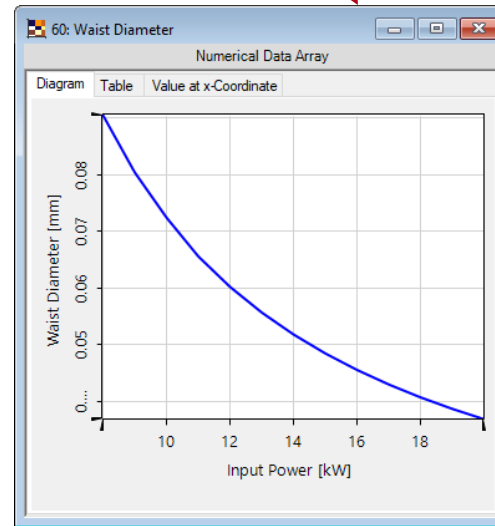

waist diameter at b

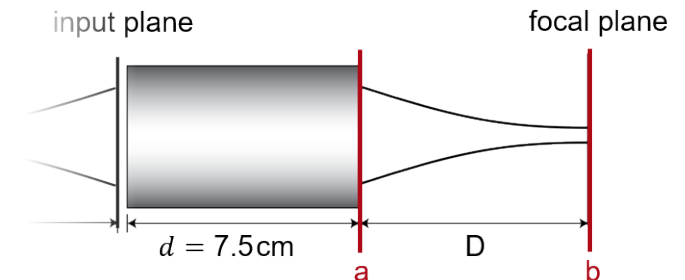

Results: (1,0) Mode

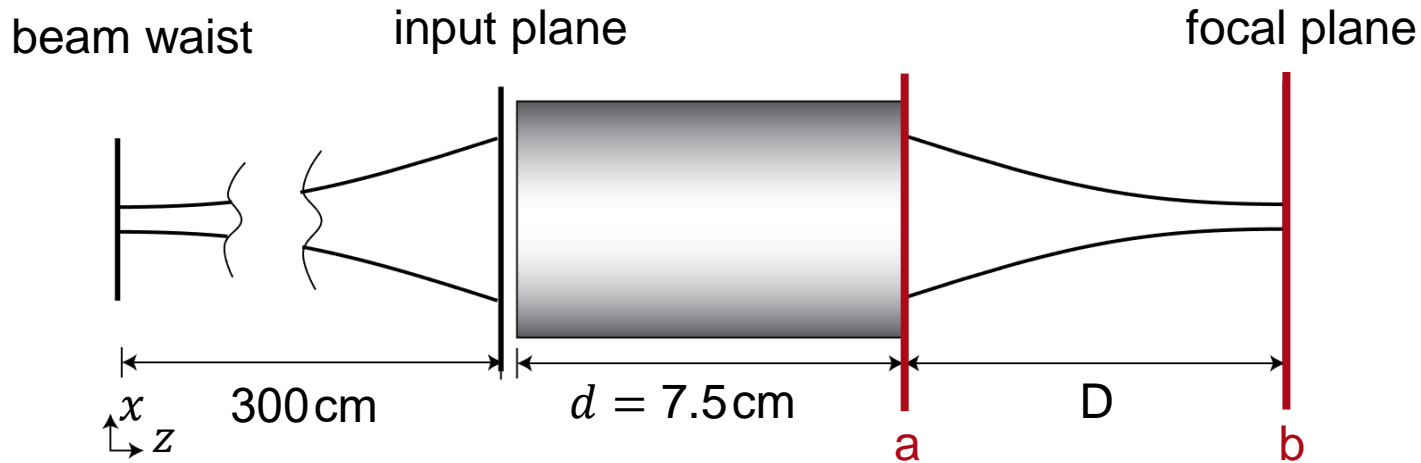

- For the thermal lens with applied 18kW the simulated distance D is 91.0mm.
- The technique to propagate fields through the thermal lens is described in [2].
- The technique to propagate fields from position a to b is diffractive propagation integral [3].

Results: (1,0) Mode

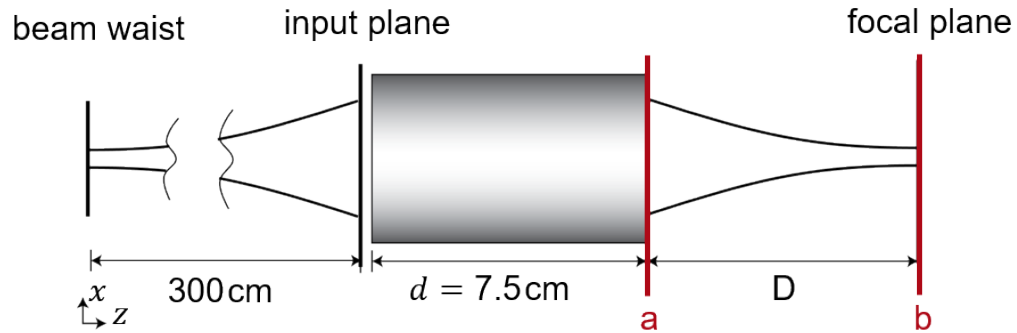

Highlight

combination of different field tracing techniques

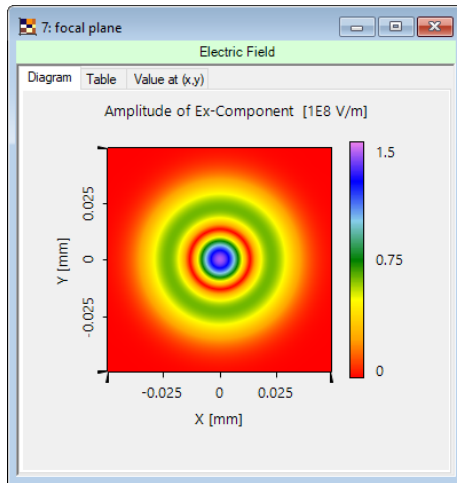

E_x

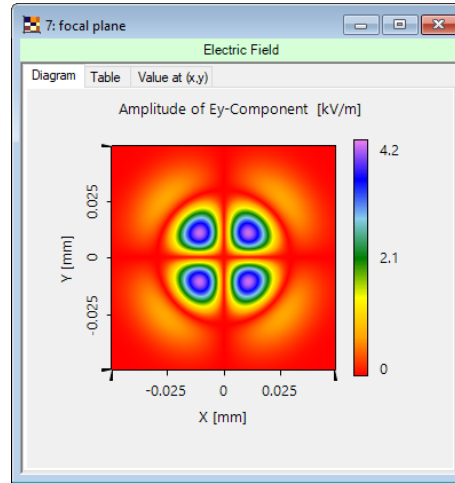

E_y

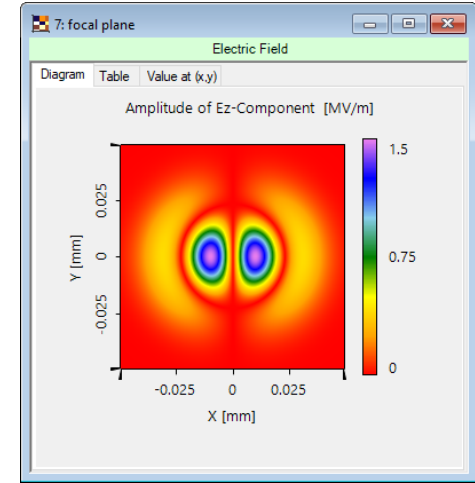

E_z

Document & Technical Info

code	BD.0008
version of document	1.0
title	Gaussian Beam Focused by Thermal Lens
category	Laser Systems > Beam Delivery Systems (BD)
author	Huiying Zhong (LightTrans)
used VL version	7.0.1.12

Specifications of PC Used for Simulation

Processor	i7-5600U (2 CPU cores)
RAM	12GB
Operating System	Windows 10